



# BAGSAN





# BAGSAN

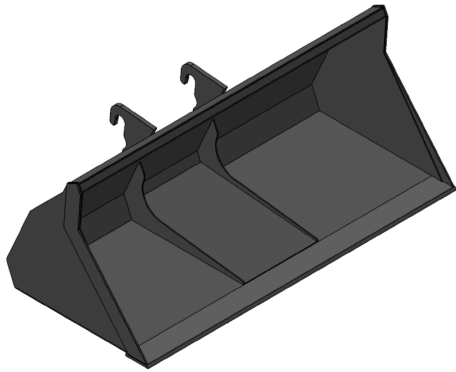

## STANDART BUCKET

Ideal for general-purpose material handling, suitable for a variety of construction and landscaping tasks.

**Width:** 2340 mm **Volume:** 1,1 m<sup>3</sup>

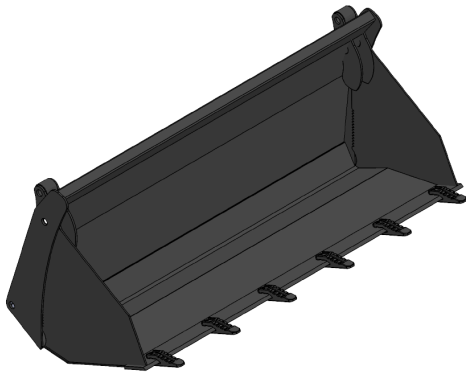

## OPENING BUCKET LARGE

Designed for efficient material handling with a wide opening mechanism, making it ideal for tasks that require quick loading and unloading.

**Width:** 2340 mm **Volume:** 1 m<sup>3</sup>

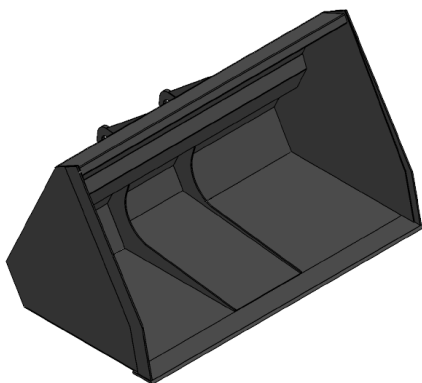

## GRAIN BUCKET

Specifically designed for handling grain and other bulk materials.

**Width:** 2340 mm **Volume:** 2,2 m<sup>3</sup>

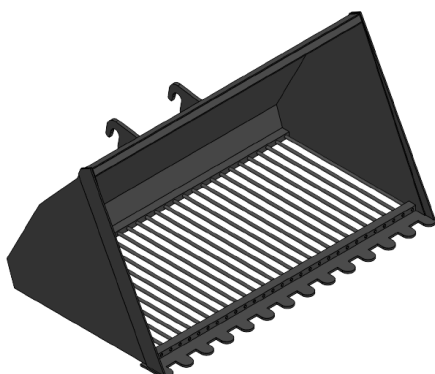

## BEET BUCKET

Engineered for the efficient handling and transport of beets and similar root crops.

**Width:** 2340 mm **Volume:** 2,2 m<sup>3</sup>

# ATTACHMENTS

---

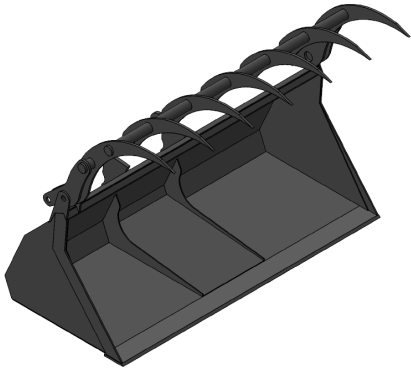

## GRAPPLE BUCKET

Ideal for handling irregularly shaped materials like logs, branches, and debris.

**Width:** 2340 mm **Volume:** 1,1 m<sup>3</sup>



## SILAGE CUTTING FORK

Designed for efficient handling and precise cutting of silage bales.

**Capacity:** Capable of gripping and cutting silage bales of 500 kg and 1000 kg.

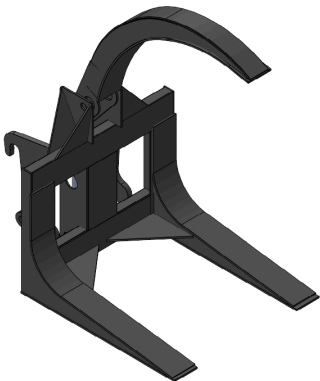

## LOG GRAPPLE FORK

Specially designed for gripping and transporting logs and large timber.

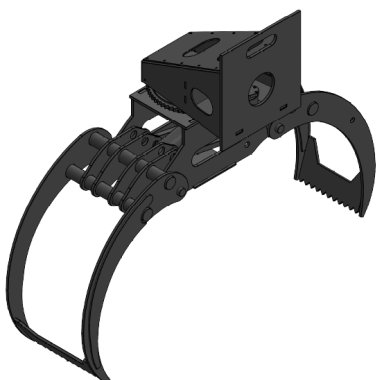

## LOG GRAPPLE 360°

Designed for versatile and precise handling of logs and timber, the 360° rotation allows for efficient operation in tight spaces.



# BAGSAN

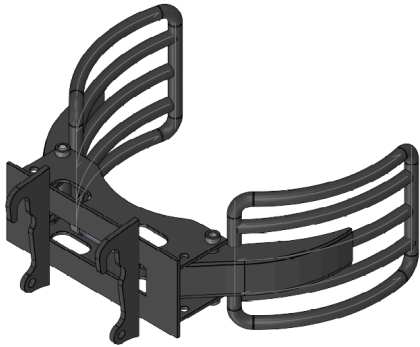

## ROLL BALE HANDLING

Perfect for handling and transporting round bales efficiently.

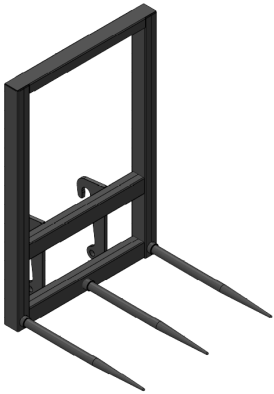

## BALE SKEWER 3 FORK

Designed for efficient and stable transportation of hay, straw, and silage bales.

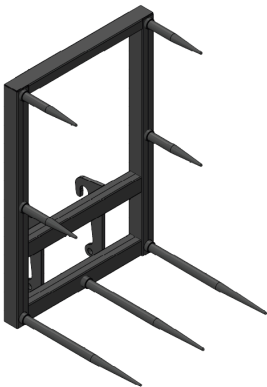

## BALE SKEWER 7 FORK

Optimized for secure and efficient handling of bales in agricultural settings. Features 3 main skewers plus 4 auxiliary mini skewers for enhanced stability.

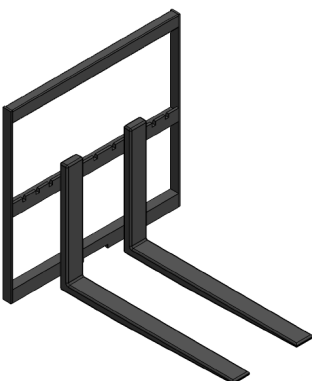

## PALLET FORK

Manually set the forks to your desired width for efficient lifting, transporting, and stacking in various industrial and agricultural environments.

# ATTACHMENTS

---

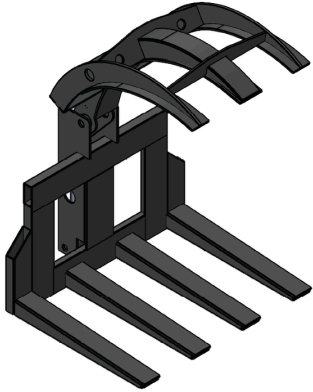

## RECYCLING MATERIAL HANDLING

Ideal for sorting, lifting, and transporting various recycling loads in waste management and recycling facilities.

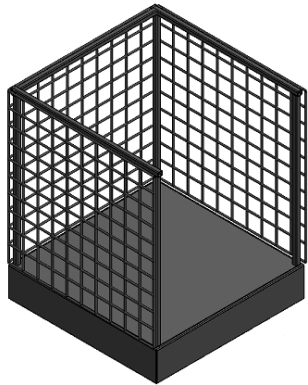

## PLATFORM BASKET SMALL

A compact, single-person basket with a 1 square meter platform for safe access to elevated areas. Ideal for tight spaces.

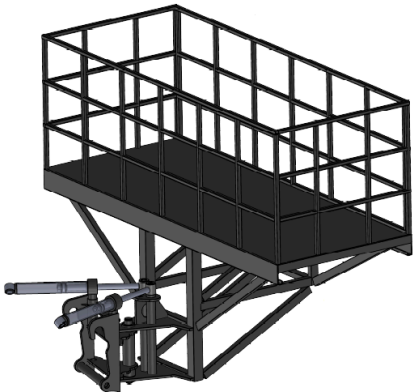

## PLATFORM BASKET LARGE

This large platform basket features a 1-meter length and 3-meter width, providing ample space for multiple tasks and enhanced stability in elevated work environments.

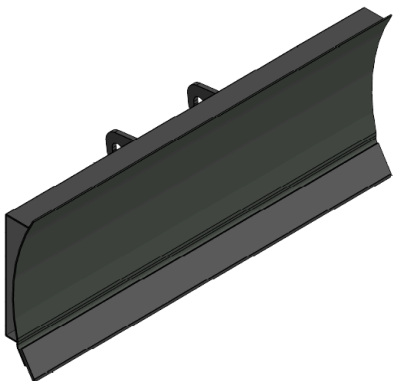

## LEVELING SHOVEL

A versatile shovel for precise leveling and grading of surfaces, suitable for construction, landscaping, agriculture, and livestock tasks.



# BAGSAN

